



## WEIGHING PROFILE & DATA

### Owners Details

Name: **Mr & Mrs Client**  
Address: **PO Box 1 Howard Springs NT 0835**  
Telephone: **0402 480 973**  
Email: **info@travellingweigh.com.au**

### Trailer/Boat Included Load At Time Of Measurement

Registration Number:

Make and Model: **Haines Hunter Boat & Trailer**

Compliance Plate: Payload: **2345** AGL: **3500** TBM: **350**  
TARE: **1155** GTM: **3320** ATM: **3500**

### Caravan Included Load At Time Of Measurement

Fishing Gear                      Eskies                      Food and Drinks                      Gas Tanks Full                      Fuel Tank Full  
Water Tanks Full  
Safety Gear

### Tow Vehicle Details

Registration Number:

Make and Model: **2022 Y62 Patrol**

Compliance Plate: BTC: **3500** GVM: **3500** GCM: **7000**  
Front Axle: **1650** Rear Axle: **2030**

### Tow Vehicle Included Load At Time Of Measurement

2 Passengers                      Fuel Tank Full                      Tool kit  
Tools 50kg approx                      Water 10L                      Empty Esky                      Blankets etc                      First Aid Kit

### Measurement Date

Date: **17/09/2023** Time: **2:06 PM** Operator: **Cameron Dyal**

This advisory weighing document cannot be used for certification or registration purposes.  
The Travelling Weigh accepts no responsibility or liability for changes in vehicle weights after the issue of these documents.

Scale Number: **AC 20220822007**

Phone: 0402 480 973  
Po Box 651 North Lakes QLD 4509

ABN 46 662 680 882

## BASE WEIGHING REPORT TRAILER/BOAT

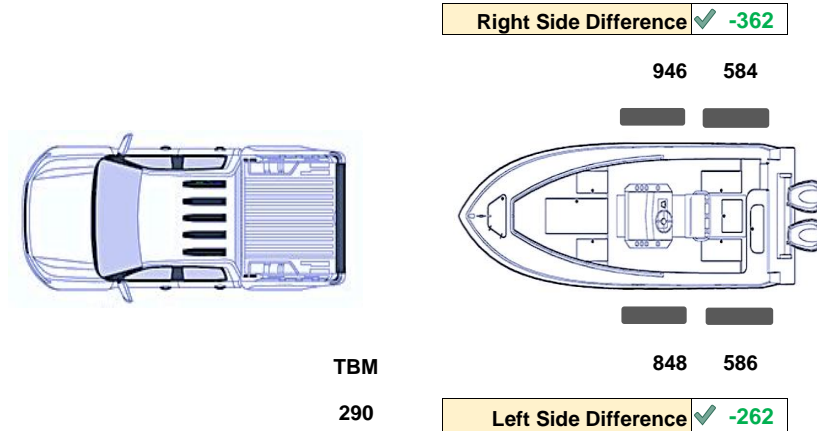

Trailer/Boat	Compliance Plate	Actual Weight	Result
<b>TBM:</b> Towball Mass	350	290	✓ -60
<b>GTM:</b> Gross Trailer Mass	3320	2964	✓ -356
<b>ATM:</b> Aggregate Trailer Mass	3500	3254	✓ -246
<b>Towball Mass Percentage</b>	TBM is		<b>8.9%</b> % of Trailer/Boat ATM

### Measurement Date

Date: **17/09/2023** Time: **2:06 PM** Operator: **Cameron Dyal**

This advisory weighing document cannot be used for certification or registration purposes.

The Travelling Weigh accepts no responsibility or liability for changes in vehicle weights after the issue of these documents.

Scale Number: **AC 20220822007**

Phone: 0402 480 973

Po Box 651 North Lakes QLD 4509

ABN 46 662 680 882

## BASE WEIGHING REPORT TOW VEHICLE

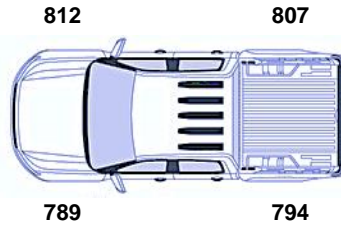

<i>Tow Vehicle (On it's Own)</i>	Compliance Plate	Actual Weight	Result
<b>GVM:</b> Gross Vehicle Mass	<b>3500</b>	<b>3202</b>	✓ <b>-298</b>
<b>Front Axle:</b> Vehicle Only	<b>1650</b>	<b>1601</b>	✓ <b>-49</b>
<b>Rear Axle:</b> Vehicle Only	<b>2030</b>	<b>1601</b>	✓ <b>-429</b>

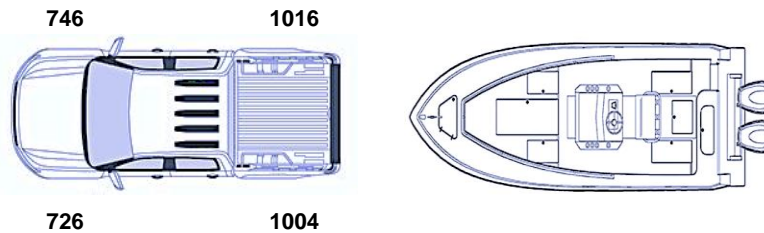

<i>Tow Vehicle in Combination</i>	Compliance Plate	Actual Weight	Available Payload
<b>BTC:</b> Braked Towing Capacity	<b>3500</b>	<b>3254</b>	✓ <b>-246</b>
<b>GVM:</b> Gross Vehicle Mass In Combination	<b>3500</b>	<b>3492</b>	✓ <b>-8</b>
<b>GCM:</b> Gross Combination Mass	<b>7000</b>	<b>6456</b>	✓ <b>-544</b>
<b>Front Axle:</b> In Combination	<b>1650</b>	<b>1471</b>	✓ <b>179</b>
<b>Rear Axle:</b> In Combination	<b>2030</b>	<b>2021</b>	✓ <b>9</b>

### Measurement Date

Date: **17/09/2023** Time: **2:06 PM** Operator: **Cameron Dyal**

This advisory weighing document cannot be used for certification or registration purposes.  
The Travelling Weigh accepts no responsibility or liability for changes in vehicle weights after the issue of these documents.

Scale Number: **AC 20220822007**

Phone: 0402 480 973

Po Box 651 North Lakes QLD 4509

ABN 46 662 680 882

## VARIATION 1 WEIGHING REPORT

Variation : 100mm Tow Ball RAISE

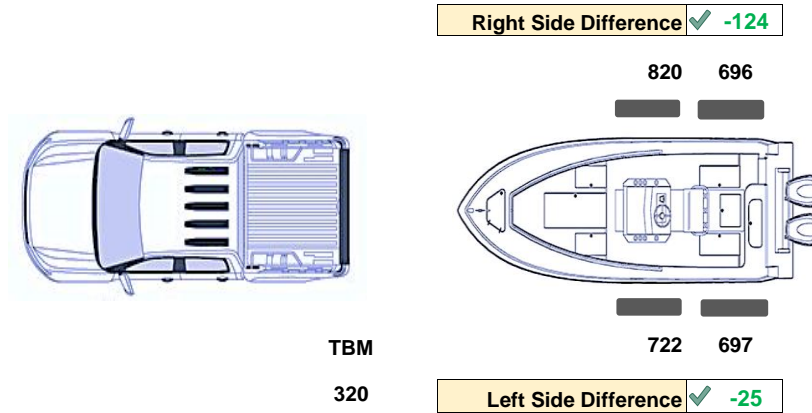

Trailer/Boat	Compliance Plate	Actual Weight	Result
<b>TBM:</b> Towball Mass	350	320	✓ -30
<b>GTM:</b> Gross Trailer Mass	3320	2935	✓ -385
<b>ATM:</b> Aggregate Trailer Mass	3500	3255	✓ -245
<b>Towball Mass Percentage</b>	TBM is <b>9.8%</b> % of Trailer/Boat ATM		

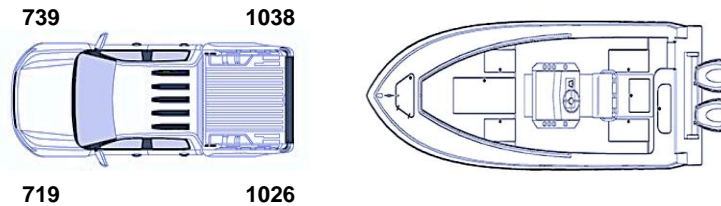

Tow Vehicle in Combination	Compliance Plate	Actual Weight	Available Payload
<b>BTC:</b> Braked Towing Capacity	3500	3255	✓ -245
<b>GVM:</b> Gross Vehicle Mass In Combination	3500	3522	✗ 22
<b>GCM:</b> Gross Combination Mass	7000	6457	✓ -543
<b>Front Axle:</b> In Combination	1650	1458	✓ 192
<b>Rear Axle:</b> In Combination	2030	2064	✗ -34

### Measurement Date

Date: **17/09/2023** Time: **2:06 PM** Operator: **Cameron Dyal**

This advisory weighing document cannot be used for certification or registration purposes.  
The Travelling Weigh accepts no responsibility or liability for changes in vehicle weights after the issue of these documents.

Scale Number: **AC 20220822007**

Phone: 0402 480 973

Po Box 651 North Lakes QLD 4509

ABN 46 662 680 882

## VARIATION 2 WEIGHING REPORT

Variation: Above + Move Gear from Car TO BOAT

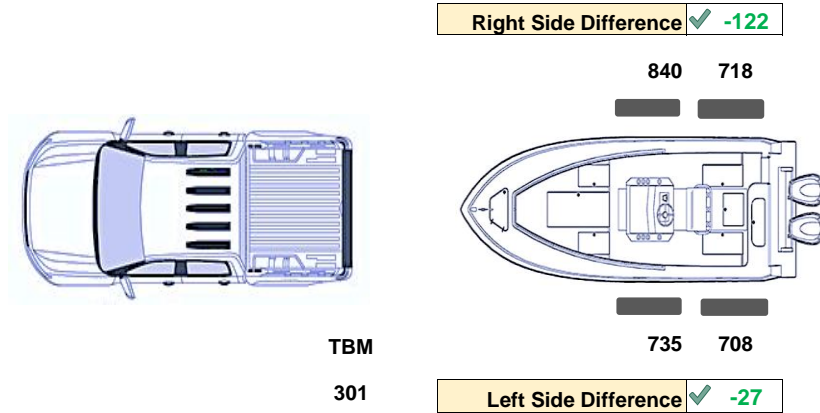

Trailer/Boat	Compliance Plate	Actual Weight	Result
<b>TBM:</b> Towball Mass	350	301	✓ -49
<b>GTM:</b> Gross Trailer Mass	3320	3001	✓ -319
<b>ATM:</b> Aggregate Trailer Mass	3500	3302	✓ -198
<b>Towball Mass Percentage</b>	TBM is 9.1% of Trailer/Boat ATM		

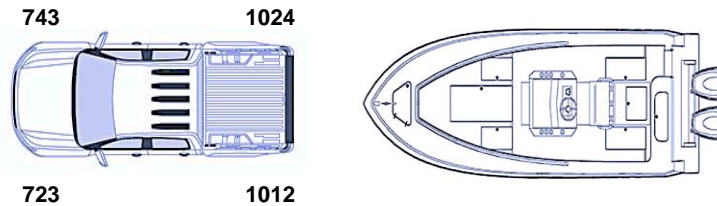

Tow Vehicle in Combination	Compliance Plate	Actual Weight	Available Payload
<b>BTC:</b> Braked Towing Capacity	3500	3302	✓ -198
<b>GVM:</b> Gross Vehicle Mass In Combination	3500	3503	✗ 3
<b>GCM:</b> Gross Combination Mass	7000	6504	✓ -496
<b>Front Axle:</b> In Combination	1650	1466	✓ 184
<b>Rear Axle:</b> In Combination	2030	2037	✗ -7

### Measurement Date

Date: 17/09/2023 Time: 2:06 PM Operator: Cameron Dyal

This advisory weighing document cannot be used for certification or registration purposes.

The Travelling Weigh accepts no responsibility or liability for changes in vehicle weights after the issue of these documents.

Scale Number: AC 20220822007

Phone: 0402 480 973

Po Box 651 North Lakes QLD 4509

ABN 46 662 680 882

## VARIATION 3 WEIGHING REPORT

Variation: Above Changes + NO WATER (ie remove)

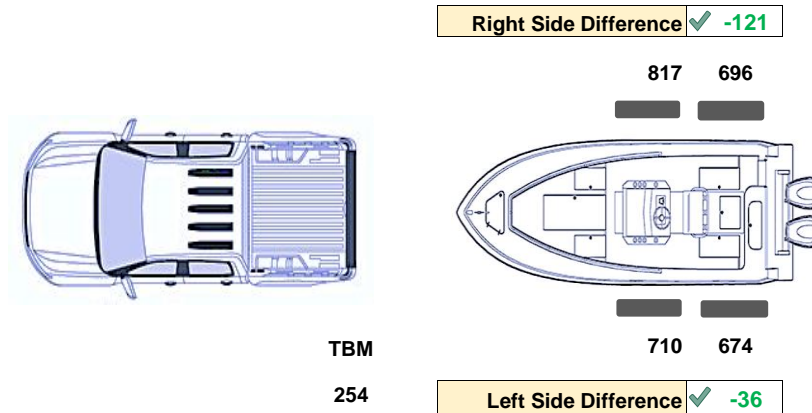

Trailer/Boat	Compliance Plate	Actual Weight	Result
<b>TBM:</b> Towball Mass	350	254	✓ -96
<b>GTM:</b> Gross Trailer Mass	3320	2897	✓ -423
<b>ATM:</b> Aggregate Trailer Mass	3500	3151	✓ -349
<b>Towball Mass Percentage</b>	TBM is <b>8.1%</b> % of Trailer/Boat ATM		

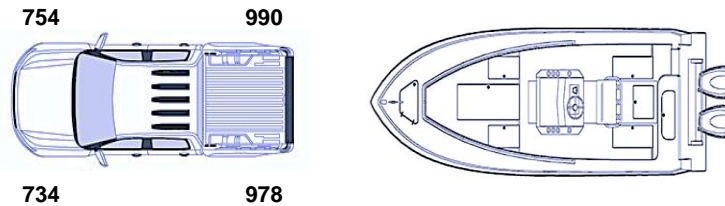

Tow Vehicle in Combination	Compliance Plate	Actual Weight	Available Payload
<b>BTC:</b> Braked Towing Capacity	3500	3151	✓ -349
<b>GVM:</b> Gross Vehicle Mass In Combination	3500	3456	✓ -44
<b>GCM:</b> Gross Combination Mass	7000	6353	✓ -647
<b>Front Axle:</b> In Combination	1650	1487	✓ 163
<b>Rear Axle:</b> In Combination	2030	1969	✓ 61

### Measurement Date

Date: **17/09/2023** Time: **2:06 PM** Operator: **Cameron Dyal**

This advisory weighing document cannot be used for certification or registration purposes.

The Travelling Weigh accepts no responsibility or liability for changes in vehicle weights after the issue of these documents.

Scale Number: **AC 20220822007**

Phone: 0402 480 973

Po Box 651 North Lakes QLD 4509

ABN 46 662 680 882